

# Pressed Reducer

Pressed reducers are precision drawn and made from extra deep drawing steel (EDDS) in accordance with ASTM-A653. Made of 24. Ga or 22 Ga. Galvanized material with a G60 coating thickness or better.

## Reducer Sizing Chart

A	B	Overall Length
8"	6"	6 ¾"
10"	6"	8 ½"
10"	8"	6 ¾"
12"	8"	8 ½"
12"	10"	6 ¾"
14"	10"	8 ½"
14"	12"	6 ¾"
16"	10"	10 ½"
16"	12"	8 ½"
16"	14"	6 ¾"

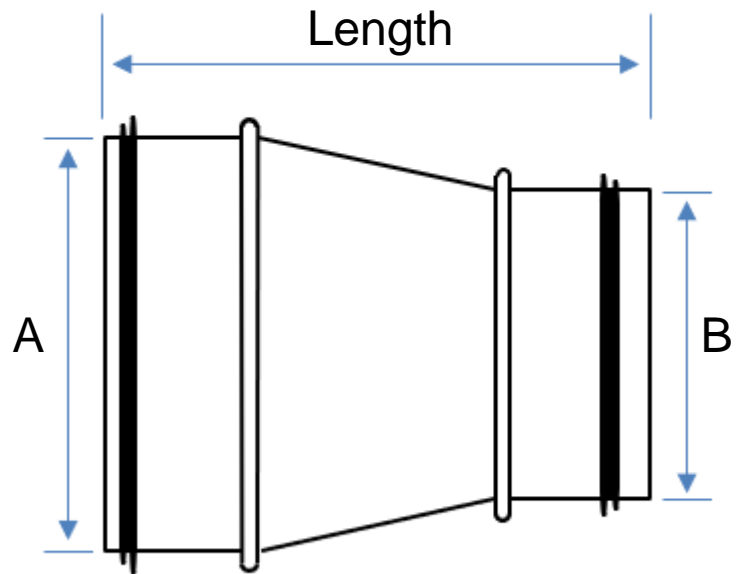

Reducers are 1.75" from bead to end of fitting.

