

Square to Round

Ducts & Cleats spiral fittings are made with a lap seam, or butt weld seam. Fabricated from G90 galvanized steel meeting ASTM-A653.

Round end can be made with:

- Standard spiral end

Square end can be made with:

- Slips and drives
- TDC
- Raw for bolt connections
- Variety of flanges or hems

Square to Round:

- Dimensions to be listed as follows: L, W, D
- Offset square to rounds available (drawing required)
- All fittings are 2" from bead to end of fitting

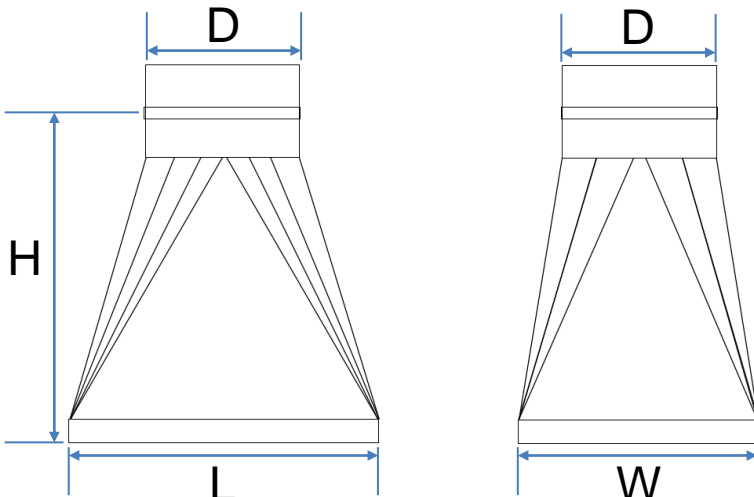

Stock Sizes

| L/W | D | H |
|-----------|-----|-----|
| 12 x 8 | 6" | 12" |
| 12 x 10 | 8" | 12" |
| 14 x 12.5 | 10" | 12" |
| 16 x 15 | 12" | 12" |
| 20 x 17.5 | 14" | 12" |
| 24 x 18 | 16" | 12" |

