

VCD-23 Low Leakage 3V Blade Volume Control Damper

APPLICATION & DESIGN

The VCD-23 is a ruggedly built low leakage control damper intended for applications in low to medium pressure and velocity systems. A wide range of electric and pneumatic actuators are available.

RATINGS

Pressure:	Up to 5 in. wg - pressure differential
Velocity:	Up to 3,000 ft/min
Leakage:	Class 1A @ 1 in. wg Class 1 @ up to 5 in. wg
Temperature:	Up to 250 F

PRODUCT DETAILS

Frame Type:	Channel
Frame Thickness:	16 ga
Material:	Galvanized
Blade Action:	Opposed
Blade Seal Material:	TPE
Axle/Linkage Material:	Steel
Axle Bearings:	Synthetic
Jamb Seal Material:	Stainless Steel
Damper Temp. Rating:	180 F

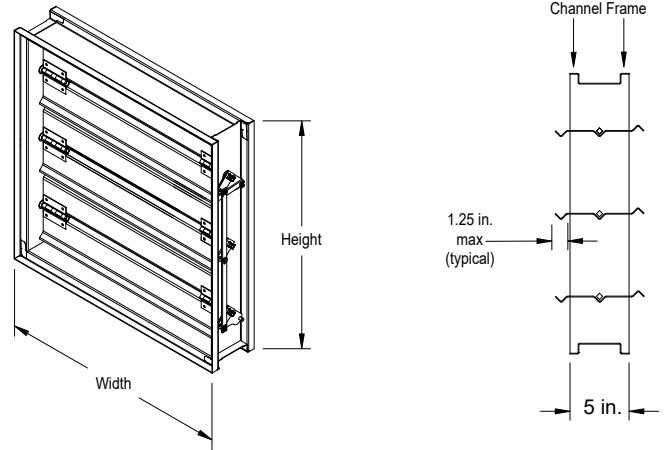

Size W x H	Belimo Model
12" x 12"	TFB
14" x 14"	TFB
16" x 16"	TFB
18" x 18"	TFB
20" x 20"	TFB
24" x 12"	TFB
24" x 16"	TFB
24" x 18"	TFB
24" x 24"	TFB
30" x 30"	FSLF
32" x 16"	TFB
32" x 32"	TSNF
36" x 24"	TSNF
36" x 36"	TSNF
48" x 24"	TSNF
48" x 48"	AFBUP

• Width and height furnished approximately 0.250 in. undersize.

Application

The VCD-23 damper is a low leakage damper intended for application in low to medium pressure and velocity systems.



Ratings

Pressure: Up to 5 in. wg (1.2 kPa) - pressure differential

Velocity: Up to 3000 fpm (15.2 m/s)

Leakage: Class 1A at 1 in. wg (.25 kPa)
Class 1at up to 5 in. wg (1.2 kPa)

Temperature: -40° to 250°F (-40°C to 121°C) Consult factory for higher temperature

Construction	Standard	Optional
Frame Material	Galvanized Steel	304SS
Frame Thickness	16 ga. (1.5mm)	12 ga. (2.7mm)*
Frame Type	5 in. x 1 in. Channel	Single Flange, Reverse Flange, Double Flange
Blade Action	Opposed	Parallel
Blade Material	Galvanized steel	304SS
Blade Thickness	16 ga. (1.5mm)	-
Blade Type	3V	-
Blade Seals	TPE	Silicone, None**
Axle Material	Plated Steel	316SS
Axle Bearings	Synthetic	316SS
Linkage Material	Plated Steel	316SS
Jamb Seal	Stainless Steel	-
Paint Finishes	Mill Finish	Baked Enamel, HI Pro Polyester, Industrial Epoxy

* W&H dimension furnished approximately 1/4 in. (6mm) undersize.

Flange Options

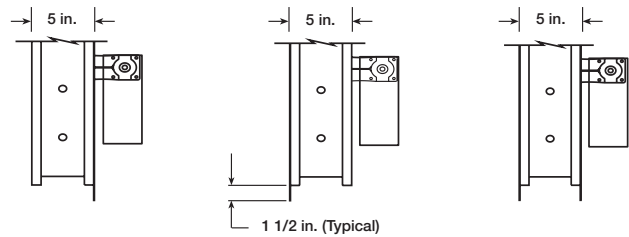

Single Flange Reversed Flange Double Flange

Shown with optional internally mounted actuator.

*When 12 ga. frame is selected and the damper height is less than 17 inches, low profile top and bottom frame members are utilized. These low profile frame members will be made from 16 ga. material.

**AMCA leakage applies when damper is provided with blade seals.

Size Limitations

W x H	Minimum Size	Maximum Size	
		Single Section	Multiple Section
Inches	6 x 6	48 x 74	Unlimited
mm	152 x 152	1219 x 1880	Unlimited

Features & Options

- Low profile head and sill are used on sizes less than 17 in. (432mm)
- Electric actuator and manual quadrant available. Factory installation available.
- Sleeves available
- 5/8 in. - 2 in. (16mm - 51mm) flange available
- Retaining angles
- Transitions- R, C and O
- Open Close Indicator (OCI)
- Security bars

Blade Operation

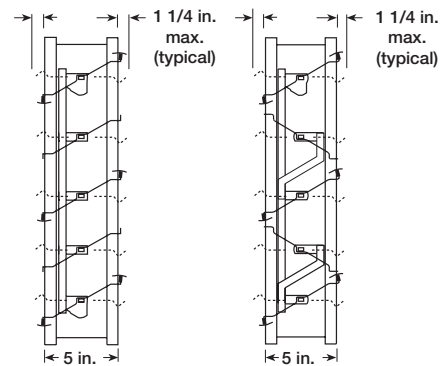

Parallel Blades

Opposed Blades

This pressure drop testing was conducted in accordance with AMCA Standard 500-D using the three configurations shown. All data has been corrected to represent standard air at a density of .075 lb/ft³(1.2 kg/m³).

Actual pressure drop found in any HVAC system is a combination of many factors. This pressure drop information along with an analysis of other system influences should be used to estimate actual pressure losses for a damper installed in a given HVAC system.

AMCA Test Figures

Figure 5.2 Illustrates a ducted damper exhausting air into an open area. This configuration has a lower pressure drop than Figure 5.5 because entrance losses are minimized by a straight duct run upstream of the damper.

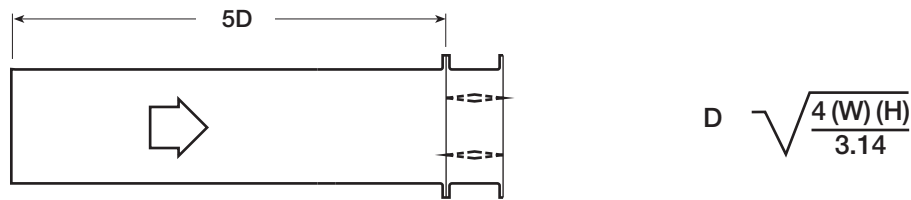

Figure 5.3 Illustrates a fully ducted damper. This configuration has the lowest pressure drop of the three test configurations because entrance and exit losses are minimized by straight duct runs upstream and downstream of the damper.

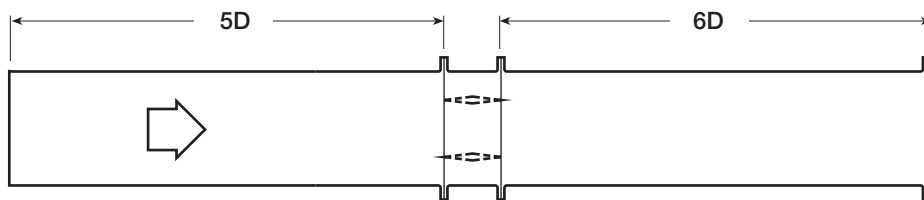
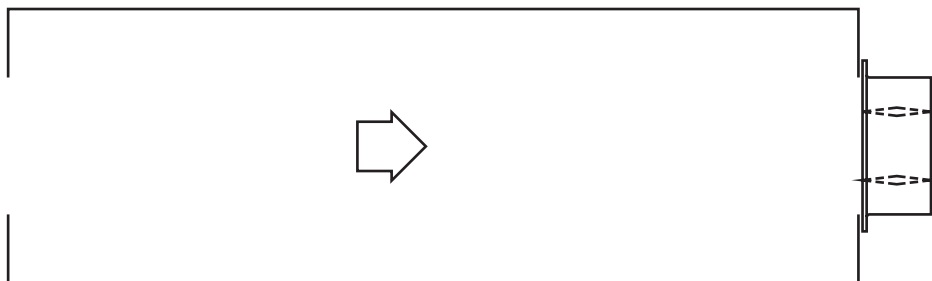

Figure 5.5 Illustrates a plenum mounted damper. This configuration has the highest pressure drop because of extremely high entrance and exit losses due to the sudden changes of area in the system.





Greenheck Fan Corporation certifies that the model VCD-23 shown herein is licensed to bear the AMCA Seal. The ratings shown are based on tests and procedures performed in accordance with AMCA Publication 511 and comply with the requirements of the AMCA Certified Ratings Programs. The AMCA Certified Ratings Seal applies to Air Leakage and Air Performance ratings.

AMCA 5.2

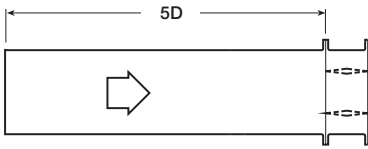

12 in. x 12 in. (305mm x 305mm)

Velocity (fpm)	Pressure Drop (in. wg)
500	0.01
1000	0.05
1500	0.11
2000	0.19
2500	0.29
3000	0.41
3500	0.55
4000	0.72

24 in. x 24 in. (610mm x 610mm)

Velocity (fpm)	Pressure Drop (in. wg)
500	0.01
1000	0.03
1500	0.06
2000	0.10
2500	0.16
3000	0.23
3500	0.30
4000	0.40

36 in. x 36 in. (914mm x 914mm)

Velocity (fpm)	Pressure Drop (in. wg)
500	0.01
1000	0.02
1500	0.05
2000	0.09
2500	0.14
3000	0.19
3500	0.27
4000	0.35

12 in. x 48 in. (305mm x 1219mm)

Velocity (fpm)	Pressure Drop (in. wg)
500	0.01
1000	0.04
1500	0.08
2000	0.15
2500	0.22
3000	0.32
3500	0.43
4000	0.56

48 in. x 12 in. (1219mm x 305mm)

Velocity (fpm)	Pressure Drop (in. wg)
500	0.01
1000	0.03
1500	0.07
2000	0.12
2500	0.18
3000	0.26
3500	0.36
4000	0.47

AMCA 5.3

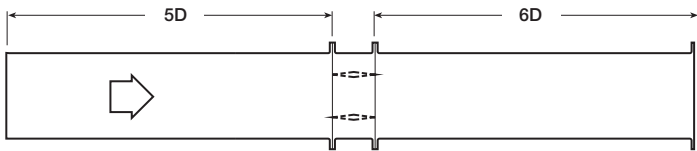

12 in. x 12 in. (305mm x 305mm)

Velocity (fpm)	Pressure Drop (in. wg)
500	0.01
1000	0.03
1500	0.08
2000	0.13
2500	0.20
3000	0.29
3500	0.40
4000	0.51

24 in. x 24 in. (610mm x 610mm)

Velocity (fpm)	Pressure Drop (in. wg)
500	0.01
1000	0.02
1500	0.04
2000	0.07
2500	0.11
3000	0.16
3500	0.21
4000	0.28

36 in. x 36 in. (914mm x 914mm)

Velocity (fpm)	Pressure Drop (in. wg)
500	0.01
1000	0.02
1500	0.03
2000	0.06
2500	0.09
3000	0.13
3500	0.19
4000	0.25

12 in. x 48 in. (305mm x 1219mm)

Velocity (fpm)	Pressure Drop (in. wg)
500	0.01
1000	0.03
1500	0.07
2000	0.12
2500	0.18
3000	0.26
3500	0.36
4000	0.46

48 in. x 12 in. (1219mm x 305mm)

Velocity (fpm)	Pressure Drop (in. wg)
500	0.01
1000	0.03
1500	0.06
2000	0.10
2500	0.16
3000	0.22
3500	0.30
4000	0.39

AMCA 5.5

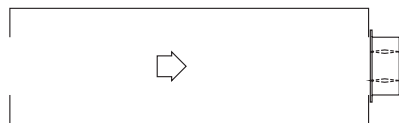

12 in. x 12 in. (305mm x 305mm)

Velocity (fpm)	Pressure Drop (in. wg)
500	0.03
1000	0.13
1500	0.30
2000	0.53
2500	0.82
3000	1.19
3500	1.62
4000	2.10

24 in. x 24 in. (610mm x 610mm)

Velocity (fpm)	Pressure Drop (in. wg)
500	0.03
1000	0.12
1500	0.26
2000	0.47
2500	0.75
3000	1.04
3500	1.41
4000	1.90

36 in. x 36 in. (914mm x 914mm)

Velocity (fpm)	Pressure Drop (in. wg)
500	0.02
1000	0.10
1500	0.22
2000	0.39
2500	0.62
3000	0.89
3500	1.21
4000	1.58

12 in. x 48 in. (305mm x 1219mm)

Velocity (fpm)	Pressure Drop (in. wg)
500	0.03
1000	0.12
1500	0.27
2000	0.47
2500	0.75
3000	1.07
3500	1.45
4000	1.91

48 in. x 12 in. (1219mm x 305mm)

Velocity (fpm)	Pressure Drop (in. wg)
500	0.03
1000	0.12
1500	0.28
2000	0.49
2500	0.77
3000	1.12
3500	1.53
4000	2.01

Air leakage is based on operation between 32°F (0°C) and 120°F (49°C).

Tested for leakage in accordance with ANSI/AMCA Standard 500-D, Figure 5.5.

Tested for air performance in accordance with ANSI/AMCA Standard 500-D, Figures 5.2, 5.3 and 5.5.

Torque

Data are based on a torque of 5.0 in.lb./ft² (0.56 N·m) applied to close and seat the damper during the test.

VCD-23	Leakage Class*		
Maximum Damper Width	1 in. wg (0.25 kPa)	4 in. wg (1 kPa)	5 in. wg (1.2 kPa)
48 in. (1219mm)	1A	1	1



Greenheck Fan Corporation certifies that the model VCD-23 shown herein is licensed to bear the AMCA Seal. The ratings shown are based on tests and procedures performed in accordance with AMCA Publication 511 and comply with the requirements of the AMCA Certified Ratings Programs. The AMCA Certified Ratings Seal applies to Air Leakage and Air Performance ratings.

*Leakage Class Definitions

The maximum allowable leakage is defined by AMCA as the following:

- Leakage Class 1A - 3 cfm/ft² at 1 in. wg (class 1A is only defined at 1 in. wg).
- Leakage Class 1
 - 4 cfm/ft² at 1 in. wg
 - 8 cfm/ft² at 4 in. wg
 - 11 cfm/ft² at 8 in. wg
 - 12.6 cfm/ft² at 10 in. wg

Velocity and Temperature Limitations

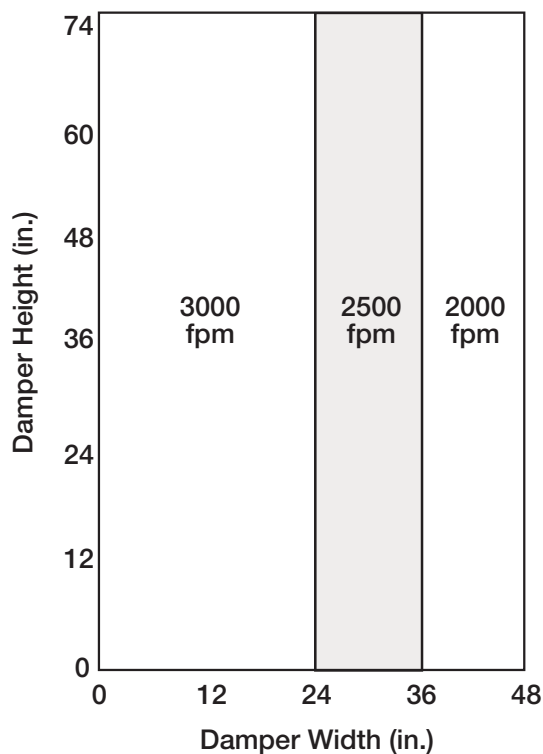

Temperature Limitations

Blade Seal	Temperature Range
TPE	-10°F to 180°F (-23°C to 82°C)
Silicone	-40°F to 250°F (-40°C to 121°C)
No Seal	-40°F to 250°F (-40°C to 121°C)

Application Data

Space Envelopes

On dampers less than 18 in. (457mm) high, actuators may also require clearances above and/or below the damper frame. “B” and “T” **dimensions are worst case clearance requirements for some dampers less than 18 in. (457mm) high**. All damper sizes under 18 in. (457mm) high do not require these worst case clearances. If space availability above or below the damper is limited, each damper size should be individually evaluated.

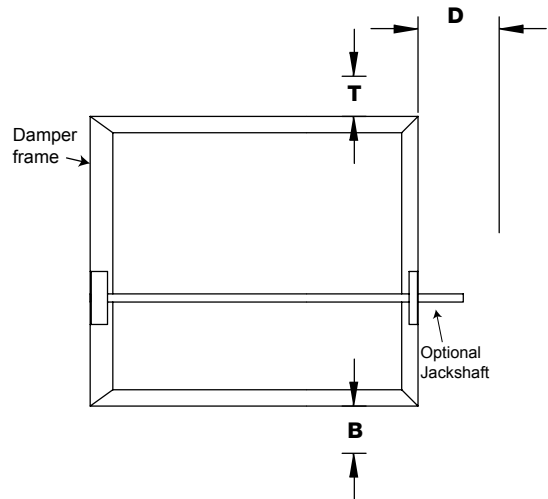

Actuator Type/Model	Height	T	B	D
	Inches (mm)			
AFBUP (-S) and FSNF Series, Belimo MSxx20 Series, Honeywell	≥6 to <10	0	12¾	6
	≥10 to <18	0	2	6
	≥18	0	0	10
FSLF, LF and TFB Series, Belimo	≥6 to <10	0	3½	6
	≥10	0	0	6
MSxx04 & MSxx09 Series, Honeywell	≥6 to <9	0	4¾	6
	≥9	0	0	6
MS75xx Series, Honeywell	≥6 to <10	0	12¾	6
	≥10 to <18	0	7	6
	≥18	0	0	6

This drawing depicts the worst case clearance requirements for an actuator with a jackshaft.

Internal mount only Actuator model	A	B	C
All except - EFB & EFCX Series	7 ¾ in (197 mm)	3 ¾ in (95 mm)	5 ⅜ in (136.5 mm)
EFB & EFCX Series	8 ½ in (216 mm)	6 in (152mm)	8 ½ in (216 mm)

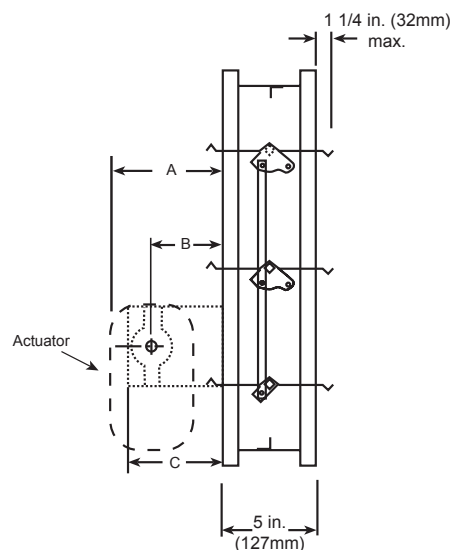

Application Data and Specifications

Multi-Section Assembly

Dampers larger than the maximum single section size, will be made up of a multiple of equal size sections. Multiple section dampers can be jackshafted together so that all sections operate together as shown below.

NOTE: Dampers larger than 48 in. x 74 in. (1219mm x 1880mm) are not intended to be structurally self supporting. Additional horizontal bracing is recommended to support the weight of the damper and vertical bracing should be installed as required to hold against system pressure.

Refer to IOM document 463384 for structural support requirements on multi-section assemblies.

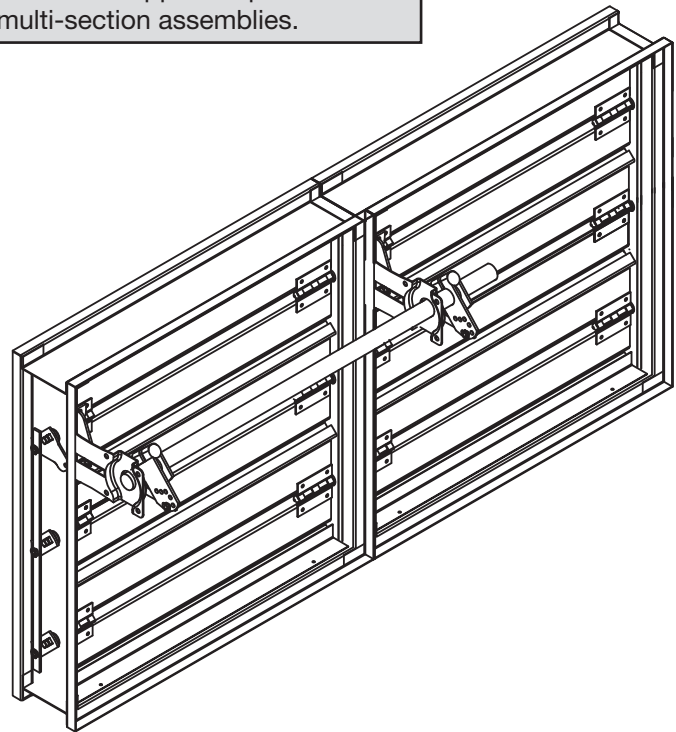

Specifications

Control dampers meeting the following specifications shall be furnished and installed where shown on plans and/or as described in schedules.

Damper blades shall be 16 ga. (1.5mm) galvanized steel 3V type with three longitudinal grooves for reinforcement. Blades shall be completely symmetrical relative to their axle pivot point, presenting identical resistance to airflow and operation in either direction through the damper (blades that are non-symmetrical relative to their axle pivot point or utilize blade stops larger than 1/2 in. [13mm] are unacceptable). Blade seals shall be TPE. Linkage shall be blade-to-blade concealed in jamb (out of the airstream) to protect linkage and reduce pressure drop and noise.

Damper frame shall be 16 ga. (1.5mm) galvanized steel formed into a structural hat channel shape with

reinforced corners to meet 11 ga. (3.1mm) criteria. Bearings shall be corrosion resistant, permanently lubricated, synthetic (acetal) sleeve type rotating in extruded holes in the damper frame for maximum service. Axles shall be square and positively locked into the damper blade. Jamb seals shall be flexible stainless steel compression type to prevent leakage between blade end and damper frame.

The damper manufacturer's submittal data shall certify all air leakage and air performance pressure drop data is licensed in accordance with the AMCA Certified Ratings Program for Test Figures 5.2, 5.3 and 5.5. Damper air performance data shall be developed in accordance with the latest edition of AMCA Standard 500-D.

Basis of design is model VCD-23.



P.O. Box 410 • Schofield, WI 54476-0410 • 715.359.6171 • greenheck.com

Copyright © 2020 Greenheck Fan Corporation

Drive Arrangement Definition

On multi-blade dampers (except vertical blade and Face & Bypass), they are given a drive arrangement code that helps describe the construction of the damper. The following breaks down what each number and letter represents.

22-2FEL-2

① ② ③ ④ ⑤ ⑥ ⑦

- ① Number of sections wide
- ② Number of sections high
- ③ Number of actuators or manual quadrants
- ④ Who supplies the actuators or manual quadrants
F - Factory
C - Customer Supplied (field mounted)
- ⑤ Actuator or manual quadrant mounting
E - External
I - Internal
B - Both internal and external
- ⑥ Actuator or manual quadrant location
L - Left hand drive
R - Right hand drive
B - Both right and left
- ⑦ Number of jackshafts

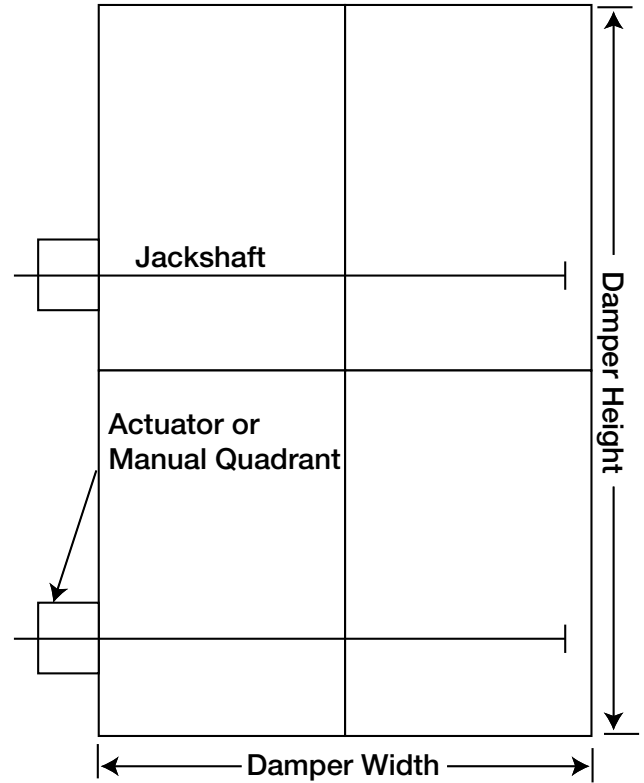

Vertical blade and face & bypass dampers are given a configuration ID number that helps describe the construction of the damper. See the following examples:

Model	Drive Arrangement Prefix
AMD-23, 33, 42	AMD
AMD-42V	VB
DFD-210, 230; DFDAF-310; DFDAF-330; SEDFD-210	MLS
FBH & FBV	FB
FSD, OFSD, CFSD, SMD, SEFSD, SSFSD, SESMD, SSSMD series (except vertical blade models)	MLS
FSD-311V, SMD-301V	VB
GFSD series	GFSD
ICD series	CC
IMO series	MLS
MBD-15 & VCD series (except vertical blade models)	CC
VCD-xxV (vertical blade models)	VB